

# USER'S MANUAL

Rev. 02/2023

# REVO S2PH

from 300A to 800A

New version 2019

012

M-RS2-300-800



**CD Automation S.r.l.**

Via Picasso, 34/36 - 20025 Legnano (MI)- Italy

Tel. +39 0331 577479 - Fax +39 0331 579479

E-mail: [info@cdautomation.com](mailto:info@cdautomation.com) - Web: [www.cdautomation.com](http://www.cdautomation.com)



# Declaration of conformity

## Declaration of conformity-Dichiarazione di Conformità

### PRODUCT MANUFACTURER/ PRODUTTORE:



**CD Automation S.R.L.**  
Controllers, Drives & Automation

Via Picasso, 34/36 - 20025 Legnano (MI)- Italy  
P.I. 08925720156 -Tel. +39 0331 577479 - Fax +39 0331 579479  
E-mail: info@cdautomation.com - Web: www.cdautomation.com

### Declare that the product / Dichiaro che il prodotto:

**Revo S 2Ph 300-800A**

PRODUCT DESCRIPTION: Electric power control  
SCOPE OF APPLICATION: Thermal control process  
DESCRIZIONE DEL PRODOTTO: Unità di controllo potenza elettrica  
UTILIZZO: Controllo processi termici

### FULFILLS THE REQUIREMENTS OF THE STANDARD:

Electrical safety Standard EN60947-1: 2007 + A1 2011, A2 2014  
EN60947-4-3: 2014  
Generic Emission standard EN60947-4-3: 2014 Group 1 Class A emissions  
Generic Immunity standard EN60947-4-3: 2014 Industrial Immunity

### SODDISFA I REQUISITI DELLA NORMA:

Specifica di sicurezza EN60947-1: 2007 + A1 2011, A2 2014  
EN60947-4-3: 2014  
Specifica sulle emissioni EN60947-4-3: 2014 gruppo 1 emissioni classe A  
Specifica sulle Immunità EN60947-4-3: 2014 Immunità industriale

CDAutomation declares that the products above mentioned are conforming to the directive  
CDAutomation dichiara che i prodotti sopra menzionati sono conformi alla direttiva  
Alla direttiva Bassa Tensione (low Voltage) **EMC directive updated 2014/30/EU,**  
**Low Voltage Directive updated 2014/35/EU**

Issued on: 20/03/2017  
Data di emissione: 20/03/2017

Amministratore Unico e  
Legale Rappresentante  
**Simone Brizzi**



# Declaration of conformity

## Declaration of conformity-Dichiarazione di Conformità



### PRODUCT MANUFACTURER/ PRODUTTORE:



**CD Automation S.R.L.**  
Controllers, Drives & Automation

Via Picasso, 34/36 - 20025 Legnano (MI)- Italy  
P.I. 08925720156 -Tel. +39 0331 577479 - Fax +39 0331 579479  
E-mail: info@cdautomation.com - Web: www.cdautomation.com

### Declare that the product / Dichiaro che il prodotto:

**Revo S 2Ph 300-800A**

PRODUCT DESCRIPTION: Electric power control  
SCOPE OF APPLICATION: Thermal control process  
DESCRIZIONE DEL PRODOTTO: Unità di controllo potenza elettrica  
UTILIZZO: Controllo processi termici

### FULFILLS THE REQUIREMENTS OF THE STANDARD:

Electrical safety Standard	EN60947-1: 2007 + A1 2011, A2 2014 EN60947-4-3: 2014
Generic Emission standard	EN60947-4-3: 2014 Group 1 Class A emissions
Generic Immunity standard	EN60947-4-3: 2014 Industrial Immunity

### SODDISFA I REQUISITI DELLA NORMA:

Specifica di sicurezza	EN60947-1: 2007 + A1 2011, A2 2014 EN60947-4-3: 2014
Specifica sulle emissioni	EN60947-4-3: 2014 gruppo 1 emissioni classe A
Specifica sulle Immunità	EN60947-4-3: 2014 Immunità industriale

CDAutomation declares that the products above mentioned are conforming to the directive  
CDAutomation dichiara che i prodotti sopra menzionati sono conformi alla direttiva  
Alla direttiva Bassa Tensione (low Voltage) **EMC directive updated 2014/30/EU,**  
**Low Voltage Directive updated 2014/35/EU**

Issued on: 07/03/2022  
Data di emissione: 07/03/2022







Amministratore Unico e  
Legale Rappresentante  
**Simone Brizzi**

# Important warnings for safety

This chapter contains important information for the safety. The not observance of these instructions may result in serious personal injury or death and can cause serious damages to the Thyristor unit and to the components system included.

*The installation should be performed by qualified persons.*

In the manual are used symbols to give more evidence at the notes of safety and operativity for the attention for the user:

	This icon is present in all the operational procedures where the Improper operation may result in serious personal injury or death by Electrical Shock Hazard Symbol (a lightning bolt in a triangle) precedes an electric shock hazard CAUTION or WARNING safety statement.
	Warning or Hazard that needs further explanation than the label on unit can provide. Consult User's Guide for further information.
	Unit is compliant with European Union directives. See Declaration of Conformity for further details on Directives and Standards used for Compliance.
	If available, unit is a Listed device per Underwriters Laboratories. It has been investigated to ANSI/UL® 508 standards for Industrial Control Switches and equivalent to CSA C22.2 #14. For more detail search for File E231578 on www.ul.com
	ESD Sensitive product, use proper grounding and handling techniques when installing or servicing product.
	Do not throw in trash, use proper recycling techniques or consult manufacturer for proper disposal.

A **“NOTE”** marks a short message to alert you to an important detail.









A **“CAUTION”** safety alert appears with information that is important for protecting your equipment and performance. Be especially careful to read and follow all cautions that apply to your application.





















A **“WARNING”** safety alert appears with information that is important for protecting you, others and equipment from damage. Pay very close attention to all warnings that apply to your application.

## Safety notes

 **WARNING!** To avoid damage to property and equipment, injury and loss of life, adhere to applicable electrical codes and standard wiring practices when installing and operating this product. Failure to do so could result in damage, injury and death.

 **AVERTISSEMENT!** Pour éviter d'endommager la propriété et l'équipement, les blessures et la perte de vie, respecter les codes électriques en vigueur et les pratiques de câblage standard au moment de l'installation et de l'utilisation de ce produit. Dans le cas contraire, cela peut entraîner la mort, des blessures graves ou des dommages.

-  **WARNING!** All service including inspection, installation, wiring, maintenance, troubleshooting, fuse or other user serviceable component replacement must be performed only by properly qualified personnel. Service personnel must read this manual before proceeding with work. While service is being performed unqualified personnel should not work on the unit or be allowed in the immediate vicinity.
-  **AVERTISSEMENT!** Tous les services, y compris l'inspection, l'installation, le câblage, l'entretien, le dépannage, le remplacement de fusibles ou d'autres composants pouvant être réparés par l'utilisateur, doivent être effectués uniquement par un personnel d'entretien qualifié. Le personnel de service doit lire ce manuel avant d'effectuer tout travail. Pendant que l'entretien est exécuté, tout personnel non qualifié ne doit effectuer de travail sur l'appareil ni se trouver à proximité.
-  **WARNING!** When in use the power controller is connected to dangerous voltages. Do not remove the protective covers without first disconnecting and preventing power from being restored while servicing the unit.
-  **AVERTISSEMENT!** Au moment de l'utilisation, le régulateur de puissance est connecté à des tensions dangereuses. Ne retirer aucun couvercle de protection sans d'abord débrancher l'appareil et ainsi empêcher l'alimentation d'être rétablie pendant l'entretien.
-  **WARNING!** Do not use in aerospace or nuclear applications.
-  **AVERTISSEMENT!** Ne pas utiliser pour les applications aérospatiales ou nucléaires.
-  **WARNING!** The units are not developed to manage capacitive and inductive loads.
-  **AVERTISSEMENT!** Les unités ne sont pas développées pour la conduite de charges capacitatives et inductives.
-  **WARNING!** The power controller's protection rating is IP20 with all covers installed and closed. It must be installed in an enclosure that provides all the necessary additional protections appropriate for the environment and application.
-  **AVERTISSEMENT!** L'indice de protection du régulateur de puissance est de IP20 lorsque les couvercles sont installés et fermés. L'appareil doit être installé dans une enceinte qui assure toute la protection supplémentaire nécessaire pour l'environnement et l'application.
-  **WARNING!** Ground the power controller via the provided protective earth grounding terminal. Verify ground is within impedance specifications. This should be verified periodically.
-  **AVERTISSEMENT!** Mise à la terre du régulateur de puissance par le biais de la borne de prise de terre de protection fournie. Vérifier que la prise de terre est conforme aux spécifications de l'impédance. Cela doit être vérifié périodiquement.
-  **WARNING!** Electric Shock Hazard: when the power controller has been energized, after shutting off the power, wait at least one minute for internal capacitors to discharge before commencing work that brings you in to contact with power connections or internal components.
-  **AVERTISSEMENT!** Risque de décharges électriques: lorsque le régulateur de puissance est mis sous tension, après avoir été éteint, attendre au moins une minute pour que les condensateurs internes se déchargent avant de commencer tout travail incluant le contact avec les connexions électriques ou les composants internes.
-  **WARNING!** The installation must be protected by electromagnetic circuit breakers or by fuses. The semiconductor fuses located inside the power controller are classified for UL as supplementary protection for semiconductor devices. They are not approved for branch circuit protection.
-  **AVERTISSEMENT!** L'installation doit être protégée par des disjoncteurs électromagnétiques ou des fusibles. Les fusibles pour semi-conducteurs situés à l'intérieur du régulateur de puissance sont classés UL comme protection supplémentaire pour les dispositifs pour semi-conducteurs. Ils ne sont pas approuvés pour la protection des circuits de dérivation.
-  **WARNING!** When making live voltage or current measurements, use proper personal protective equipment for the voltages and arc-flash potentials involved.

-  **AVERTISSEMENT!** Au moment de relever des mesures de tension ou de courant en direct, utiliser un équipement de protection individuelle approprié pour les tensions et les potentiels d'arc électrique concernés.
-  **WARNING!** Verify the voltage and current ratings of the power controller are correct for the application.
-  **AVERTISSEMENT!** Vérifier que les valeurs de tension et de courant du régulateur de puissance sont correctes pour l'application.
-  **CAUTION:** To avoid compromising the insulation, do not bend wire or other components beyond their bend radius specifications.
-  **ATTENTION:** Pour éviter de compromettre l'isolation, ne pas plier le fil ou tout autre composant au-delà de ses spécifications en matière de rayon de courbure.
-  **CAUTION:** Protect the power controller from high temperature, humidity and vibrations.
-  **ATTENTION:** Protéger le régulateur de puissance contre les températures élevées, l'humidité et les vibrations.
-  **CAUTION:** The power controller warranty is void if the tested and approved fuses are not used.
-  **ATTENTION:** La garantie du régulateur de puissance est nulle si aucun fusible testé et approuvé n'est utilisé.
-  **CAUTION:** Only trained and authorized personnel should access and handle the internal electronics and they must follow proper electro-static prevention procedures.
-  **ATTENTION:** Seul le personnel formé et autorisé peut accéder aux composants électroniques internes et les gérer, et il doit se conformer à des procédures de prévention électrostatique appropriées.
-  **CAUTION:** Install an appropriately sized RC filter across contactor coils, relays and other inductive loads.
-  **ATTENTION:** Installer un filtre RC de dimensions appropriées sur les bobines du contacteur, les relais et autres charges par induction.
-  **CAUTION:** The thyristor units here described have been designed for use with sinusoidal networks with nominal frequency 50-60 Hz. Any application with NON-SINUSOIDAL, distorted or disturbed networks could compromise the correct operation of the unit.
-  **ATTENTION:** Les unités de thyristors décrites ici ont été conçues pour être utilisées avec des réseaux sinusoïdaux d'une fréquence nominale de 50 à 60 Hz. Toute application utilisant des réseaux NON SINUSOÏDAUX, déformés ou perturbés peut compromettre le bon fonctionnement de l'appareil.
-  **NOTE:** Provide a local disconnect to isolate the power controller for servicing.
-  **REMARQUE:** Fournir une déconnexion locale afin d'isoler le régulateur de puissance pour l'entretien.
-  **NOTE:** The nominal current is specified for ambient temperatures at or below 40° C. Ensure the application design allows for adequate cooling of each power controller. The power controller must be mounted vertically. The cooling design must prevent air heated by one power controller from causing power controllers mounted above to exceed the ambient operating temperature limit. When power controllers are mounted side by side allow a minimum spacing of 15mm between them.
-  **REMARQUE:** Le courant nominal est précisé pour des températures ambiantes égales ou inférieures à 40°C. S'assurer que la conception de l'application permette le refroidissement adéquat de chaque régulateur de puissance. Le régulateur de puissance doit être monté verticalement. La conception de refroidissement doit empêcher l'air chauffé par le régulateur de puissance de dépasser la limite de température de fonctionnement ambiante de la part des régulateurs de puissance montés au-dessus. Lorsque les régulateurs de puissance sont montés côte à côte, il faut conserver un espacement minimal de 15 mm entre les deux.
-  **NOTE:** Use only copper cables and wires rated for use at 75°C or greater.
-  **REMARQUE:** N'utiliser que des câbles et des fils en cuivre pour l'utilisation à 75°C ou plus.



## Maintenance

In order to have a corrected cooling, the user must clean the heat-sink and the protective grill of the fans. The frequency of this servicing depends on environmental pollution.

Also check periodically if the screw for the power cables and safety earth are tightened correctly (See Connection Diagram)

### Warranty condition

Producer gives a 12 months warranty to its products.

The warranty is limited to repairing and parts substitution in our factory and does not include products not properly used and fuses.

Warranty does not include products with serial numbers deleted. The faulty product should be shipped to Producer at customer's cost and our Service will evaluate if product is under warranty terms.

Substituted parts remain of Producer property.



CD Automation srl assumes no liability for any damage to persons or property deriving from tampering, from incorrect or improper use, or from any use not conforming to the characteristics of the controller and to the instructions in this User Manual.



## Return Material Authorization (RMA)

Customers wishing to return any items, whether they are incorrectly supplied, faulty or damaged in transit, must first complete a Return Material Authorisation (RMA) form to obtain an RMA number from the Service Department.

A full repair service is available for customers. Prior to submitting the RMA form and returning products, customers are recommended to contact the technical support team to determine whether the issue can be resolved with telephone support.

### How the RMA service works

The RMA form and details are available on our web sites:

<https://www.cdautomation.com/returns-material-authorisation/>

When completing the RMA form, please be as specific as possible about the problem, including any pertinent application details. The more information given, the more quickly and more thoroughly the problem can be solved. The minimum information required is:

1. The Full Model Number
2. Quantity of units being returned
3. The units Serial Number(s)
4. A description of the problem ( "faulty" or "unknown" is not sufficient)



# Summary

- Declaration of conformity. . . . . 3
- Important warnings for safety . . . . . 4
- Maintenance . . . . . 7
- 1 Basic Connections and sizing . . . . . 10
- 2 Identification and Order Code . . . . . 11
  - 2.1 Identification of the unit . . . . . 11
  - 2.2 Order Code. . . . . 12
- 3 Technical Specifications. . . . . 13
  - 3.1 General features . . . . . 13
  - 3.2 Input features . . . . . 13
  - 3.3 Output features (power device) . . . . . 13
  - 3.4 Fan Specification . . . . . 14
  - 3.5 Environmental installation conditions . . . . . 14
  - 3.6 Derating Curve and Thermal conditions . . . . . 14
  - 3.7 Calculating flow capacity of the fan. . . . . 15
- 4 Installation . . . . . 16
  - 4.1 Dimensions and weight . . . . . 17
  - 4.2 Fixing holes . . . . . 17
- 5 Wiring instructions . . . . . 18
  - 5.1 Removing the cover . . . . . 18
  - 5.2 Line power and Load cable/bar dimensions and torque (suggested). . . . . 18
  - 5.3 Cable dimensions (suggested) of Earth and of the Command Terminals . . . . . 19
  - 5.4 Terminals Positions . . . . . 20
  - 5.5 Power Terminals . . . . . 21
  - 5.6 Control Terminals. . . . . 23
  - 5.7 Schematic (S14: 300-700A). . . . . 24
  - 5.8 Connection Diagram for 3 phases (control on 2 phases) (Size S14) . . . . . 26
  - 5.9 Schematic (S16: 800A) . . . . . 27
  - 5.10 Connection Diagram for 3 phases (control on 2 phases) (Size S16) . . . . . 29



<b>6</b>	<b>Led status and alarms</b> . . . . .	<b>30</b>
<b>7</b>	<b>Heater Break alarm and SCR short circuit</b> . . . . .	<b>31</b>
	7.1 Heater break Calibration procedure. . . . .	31
<b>8</b>	<b>Input Setting</b> . . . . .	<b>32</b>
<b>9</b>	<b>Burst Firing settings</b> . . . . .	<b>33</b>
<b>10</b>	<b>Firing type</b> . . . . .	<b>34</b>
	10.1 Zero Crossing (ZC) with SSR input . . . . .	34
	10.2 Burst Firing (BF) with Analog Input. . . . .	34
<b>11</b>	<b>Supply the electronic board</b> . . . . .	<b>35</b>
<b>12</b>	<b>Internal Fuse</b> . . . . .	<b>36</b>

# 1 Basic Connections and sizing

Star wiring with resistive load (control on two phases)

$$I = \frac{P}{1,73V}$$

V = Nominal voltage of the load

I = Nominal current of the load

P = Nominal power of the load

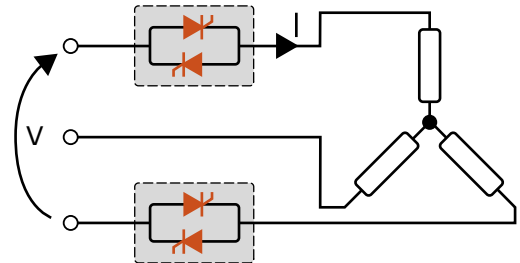

Delta wiring with resistive load (control on two phases)

$$I = \frac{P}{1,73V}$$

V = Nominal voltage of the load

I = Nominal current of the load

P = Nominal power of the load

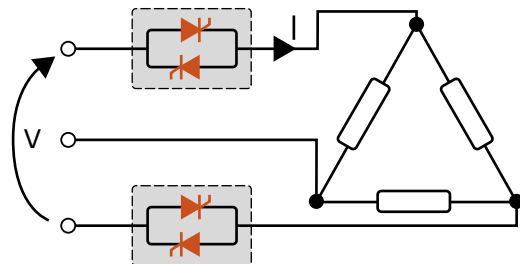

## 2 Identification and Order Code

### 2.1 Identification of the unit



**Caution:** Before to install, make sure that the Thyristor unit have not damages. If the product has a fault, please contact the dealer from which you purchased the product.

The identification's label give all the information regarding the factory settings of the Thyristor unit, this label is on the unit, like represented in figure.

Verify that the product is the same thing as ordered.



## 2.2 Order Code

	1	2	3	4	5	6	7	8	9	10	11	12	13	14	15	16
REVO S 2PH	R	s	2	-	-	-	-	-	-	-	-	-	-	-	-	-

CURRENT	4	5	6
description	code		
300A	3	0	0
400A	4	0	0
450A	4	5	0
500A	5	0	0
600A	6	0	0
700A	7	0	0
800A	8	0	0

MAX VOLTAGE	7
description	code
480V	4
600V	6
690V	7

VOLTAGE SUPPLY AUX	8	
> 210A	code	
Main Supply Voltage	Aux Voltage Range	
100/120Vac	90 to 135V Vac	1
200/208/230/240Vac	180 to 265V Vac	2
277Vac	238 to 330V Vac	3
380/415/480Vac	342 to 528V Vac	5
600Vac	540 to 759V Vac	6
690Vac	540 to 759V Vac	7

INPUT	9
description	code
SSR	S
0:10V dc	V
4:20mA	A

FIRING	10
description	code
Zero Crossing	Z
Burst Firing 4 Cycles On at 50% Power Demand	4
Burst Firing 8 Cycles On at 50% Power Demand	8
Burst Firing 16 Cycles On at 50% Power Demand	6

CONTROL MODE	11
description	code
Open Loop	0

FUSES & OPTION	12
description	code
Fixed Fuses Std for all Units > 40A	F
Fixed Fuses Std + CT + HB	H

FAN VOLTAGE	13
description	code
Fan 115Vac	1
Fan 230Vac Std Version	2
Fan 24Vdc	3

APPROVALS	14
description	code
CE EMC For European Market	0
CE EMC + cUL <sup>®</sup> listed and cULus 508 <sup>®</sup> listed	L

MANUAL	15
description	code
None	0
Italian	1
English	2
German	3
French	4

VERSION	16
description	code
Std version	1
High Sensitivity HB below 5A	5

# 3 Technical Specifications

## 3.1 General features

Cover and Socket material: PolymericV2  
 Utilization Category: AC-51 AC-55b AC-56A  
 IP Code (300-500A): 20  
 IP Code (600-800A): 00  
 Method of Connecting: Load in Delta, Load in Star  
 Auxiliary voltage:  
 Order code RS2\_ \_ \_ -\_1 = line voltage 100/120V voltage range 90:135V (8 VA Max)  
 Order code RS2\_ \_ \_ -\_2 = line voltage 200/208/220/230/240V voltage range 180:265V (8 VA Max)  
 Order code RS2\_ \_ \_ -\_3 = line voltage 277 voltage range 238:330V (8 VA Max)  
 Order code RS2\_ \_ \_ -\_5 = line voltage 380/400/415/440/480V voltage range 342:528V (8 VA Max)  
 Order code RS2\_ \_ \_ -\_6 = line voltage 600V voltage range 540:759V (8 VA Max)  
 Order code RS2\_ \_ \_ -\_7 = line voltage 690V voltage range 540:759V (8 VA Max)  
 Relay output for Heater Break Alarm: 0.5A a 125VAC  
 (only with HB option)

## 3.2 Input features

Analogic Input V: 0 ÷ 10Vdc impedance 15 kΩ  
 Analogic Input A: 4 ÷ 20mA impedance 100 Ω  
 Potentiometer: 10 kΩ min.  
 Digital Input: 4 ÷ 30Vdc 5mA Max (ON ≥4Vdc OFF <1Vdc)  
 3Hz Max duty cycle min. 100 ms

## 3.3 Output features (power device)

Current (A)	Nominal Voltage range (Ue) (V)	Repetitive peak reverse voltage (Uimp)		Latching current (mAeff)	Max peak one cycle (10 msec.) (A)	Leakage current (mAeff)	FUSE I <sup>2</sup> T value Suggested A2s (at 500V) tp= 10msec	Frequency range (Hz)	Power loss Thyristor + Fuse I=Inom (W)	Isolation Voltage (Ui) (A)
		(480V)	(600V)							
300	24÷600	1200	1600	200	7800	15	73500	47÷70	903	3000
400	24÷600	1200	1600	200	7800	15	149000	47÷70	1092	3000
450	24÷600	1200	1600	200	7800	15	215600	47÷70	1259	3000
500	24÷600	1200	1600	200	8000	15	215600	47÷70	1407	3000
600	24÷600	1200	1600	1000	17800	15	294000	47÷70	1528	3000
700	24÷600	1200	1600	1000	17800	15	294000	47÷70	1753	3000
800	24÷600	1200	1600	1000	15000	15	246400	47÷70	2281	2500

### 3.4 Fan Specification

Supply	Size	Number of fans 	Number of fans 
230Vac Standard	S14 300A,400A, 500A, 600A	Two Fans - (16W x 2) 32W	Four Fans - (16W x 4) 64W
	S14 450A, 700A	Four Fans - (16W x 4) 64W	Four Fans - (16W x 4) 64W
	S16 800A	Four Fans - (16W x 4) 64W	Four Fans - (16W x 4) 64W
115Vac Option	S14 300A, 400A, 500A, 600A	Two Fans - (14W x 2) 28W	Four Fans - (14W x 4) 56W
	S14 450A, 700A	Four Fans - (14W x 4) 56W	Four Fans - (14W x 4) 56W
	S16 800A	Four Fans - (14W x 4) 56W	Four Fans - (14W x 4) 56W
24Vdc Option	S14 300A, 400A, 500A, 600A	Two Fans - (7W x 2) 14W	Four Fans - (7W x 4) 28W
	S14 450A, 700A	Four Fans - (7W x 4) 28W	Four Fans - (7W x 4) 28W
	S16 800A	Four Fans - (7W x 4) 28W	Four Fans - (7W x 4) 28W

### 3.5 Environmental installation conditions

- Ambient temperature 0-40°C (32-104°F) at nominal current. Over 40°C (104°F) use the derating curve (max 50°C).
- Storage temperature -25°C to 70°C -13°F to 158°F
- Installation place Don't install at direct sun light, where there are conductive dust, corrosive gas, vibration or water and also in salty environmental.
- Altitude Up to 1000 meter over sea level. For higher altitude reduce the nominal current of 2% for each 100m over 1000m
- Humidity From 5 to 95% without condense and ice
- Pollution Level Up to 2nd Level ref. IEC 60947-1 6.1.3.2

### 3.6 Derating Curve and Thermal conditions

The nominal current of the units in specification are referred to continuous service at 40°C ambient temperature. For higher temperature multiply the nominal current times derating coefficient K as represented in the graph.

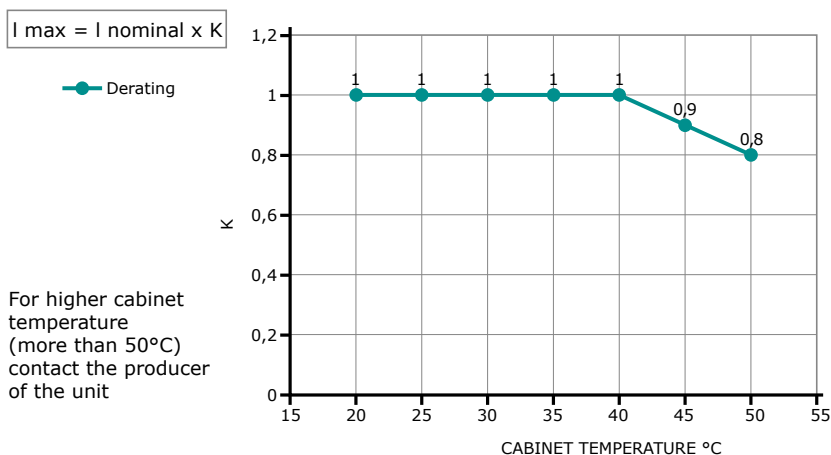

Operation at ambient operating temperature above 40°C not covered by UL®

### 3.7 Calculating flow capacity of the fan

All the thyristor units when are in conduction produces power loss that is dissipated inside cubicle in terms of heating. Due to this fact the internal temperature of cubicle is higher than ambient temperature. To be cooled the thyristor need of fresh air cooling and to do it is normally used a fan mounted on the front door or on the roof of the cabinet.

Procedure to size **Fan air mass flow (V)**: see *power loss for each thyristor and fuse mounted indicated in the manual related to the current (Output feature and Internal fuse Chapter)*.

$V=f * \frac{Q_v}{t_c-t_a}$	<p><b>Qv</b> = total power losses (w) (thyristor + fuse power loss)</p> <p><b>ta</b> = ambient temperature (°C)</p> <p><b>tc</b> = cabinet temperature (°C)</p> <p><b>V</b> = fan air mass flow (m3/h)</p> <p><b>f</b> = altitude coefficient (see table on right)</p>	<p><b>Altitude</b></p> <p>0:100 meters f = 3.1 m3k/W/h</p> <p>100:250 meters f = 3.2 m3k/W/h</p> <p>250:500 meters f = 3.3 m3k/W/h</p> <p>500:750 meters f = 3.4 m3k/W/h</p>
-----------------------------	--	--



The formulas used are for information only and is not a substitute for a proper thermal rating done by a qualified person.

# 4 Installation

Before to install, make sure that the Thyristor unit have not damages.

If the product has a fault, please contact the dealer from which you purchased the product. Verify that the product is the same thing as ordered.

The Thyristor unit must be always mounted in vertical position to improve air cooling on heat-sink.

**Maintain the minimum distances (\*) in vertical and in horizontal as represented, *this area must be free from obstacle (wire, copper bar, plastic channel).***

When more unit has mounted inside the cabinet maintain the air circulation like represented in figure without obstacle for the air flow. Is necessary to install a fan to have better air circulation as calculated previously.

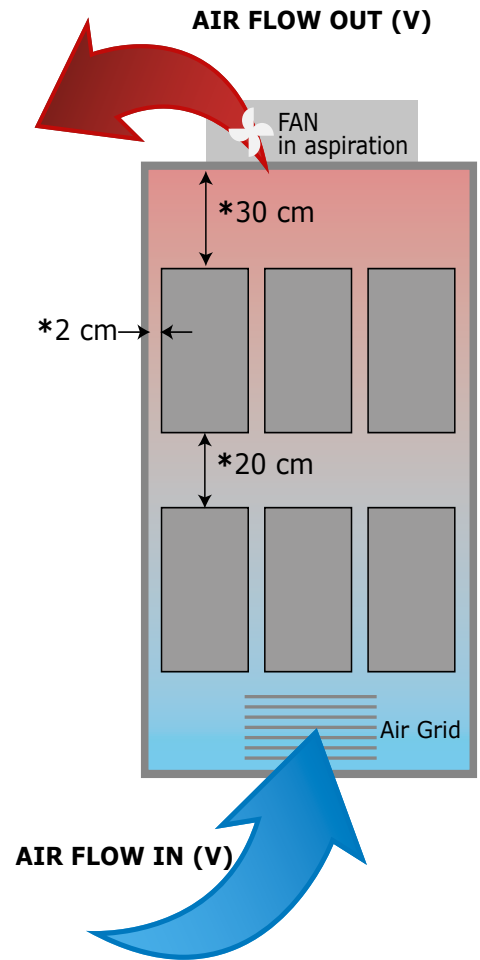

The V Air flow must be equal or more than the value calculated.

If the cabinet fan mounted by the customer have an air flow lower than the correct value the warranty will decay.



### 4.1 Dimensions and weight

REVO S 2PH 300A÷700A (S14)  
 W 262mm - H 520mm - D 270mm  
 Weight 22 kg



REVO S 2PH 800A (S16)  
 W 275mm - H 560mm - D 270mm  
 Weight 34.4 kg

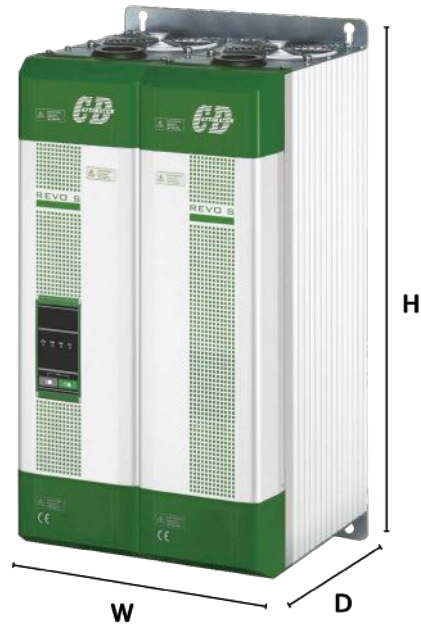

### 4.2 Fixing holes

REVO S 2PH 300A÷700A (S14)

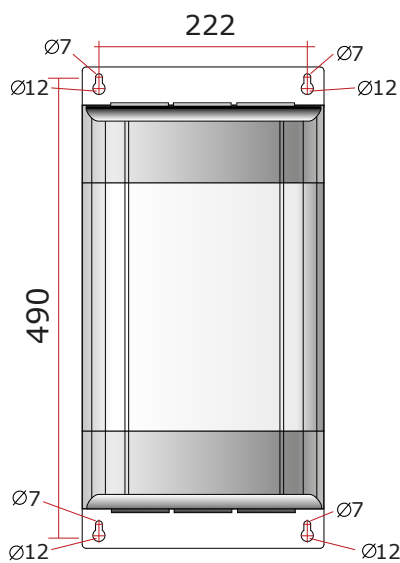

REVO S 2PH 800A (S16)

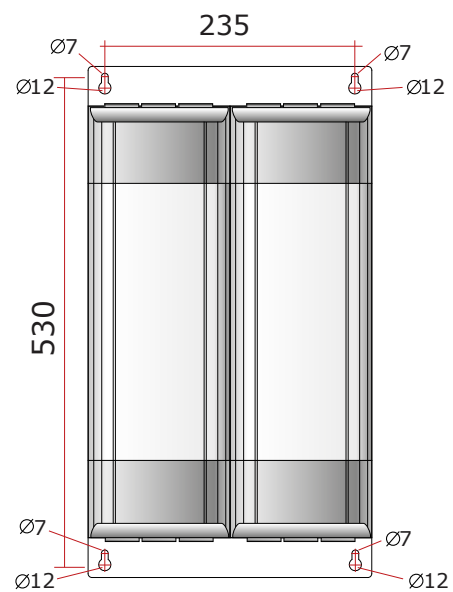

# 5 Wiring instructions

The Thyristor unit could be susceptible to interferences lost by near equipments or by the power supply, for this reason in accord to the fundamental practices rules is opportune take some precautions:

- The coil contactor, the relays and other inductive loads must be equipped with opportune RC filter.
- Use shielded bipolar cables for all the input and output signals.
- The signal cables must not be near and parallel to the power cables.
- Local regulations regarding electrical installation should be rigidly observed.

Use copper cables and wires rated for use at 75°C only.

## 5.1 Removing the cover

Instructions for open the thyristor unit



## 5.2 Line power and Load cable/bar dimensions and torque (suggested)

Current	Connector Type	Torque		Cable			Cable Terminal	Bar
		Lb-in	Nm	AWG	mm <sup>2</sup>	kcmil		
300A (S14)	Power field wiring Bus Bar with M10 screw	265	30.0	2 x 1/0	2 x 70	350	UL Listed (ZMVV) Copper Tube Crimp. Lug	Bus bar 30x6mm
400A (S14)	Power field wiring Bus Bar with M10 screw	265	30.0	2 x 3/0	2 x 95	600	UL Listed (ZMVV) Copper Tube Crimp. Lug	Bus bar 30x6mm
450A (S14)	Power field wiring Bus Bar with M10 screw	265	30.0	2 x 4/0	2 x 95	700	UL Listed (ZMVV) Copper Tube Crimp. Lug	Bus bar 30x6mm
500A (S14)	Power field wiring Bus Bar with M10 screw	265	30.0	-	2 x 150	2x250 900	UL Listed (ZMVV) Copper Tube Crimp. Lug	Bus bar 60x4mm
600A (S14)	Power field wiring Bus Bar with M10 screw	265	30.0	-	2 x 185	2x350 1500	UL Listed (ZMVV) Copper Tube Crimp. Lug	Bus bar 60x5mm
700A (S14)	Power field wiring Bus Bar with M10 screw	265	30.0	-	2 x 300	2x500	UL Listed (ZMVV) Copper Tube Crimp. Lug	Bus bar 60x6mm
800A (S16)	Power field wiring Bus Bar with M10 screw	265	30.0	-	2 x 300	2x500	UL Listed (ZMVV) Copper Tube Crimp. Lug	Bus bar 60x6mm

### 5.3 Cable dimensions (suggested) of Earth and of the Command Terminals

Current	Earth			Command Terminals	
	Cable		Screw	Cable	
	mm <sup>2</sup>	AWG	M	mm <sup>2</sup>	AWG
300A (S14)	50	1	M8	0,50	18
400A (S14)	50	1	M8	0,50	18
450A (S14)	70	1/0	M8	0,50	18
500A (S14)	70	1/0	M8	0,50	18
600A (S14)	70	1/0	M8	0,50	18
700A (S14)	70	1/0	M8	0,50	18
800A (S16)	70	1/0	M8	0,50	18

### 5.4 Terminals Positions

Size S14

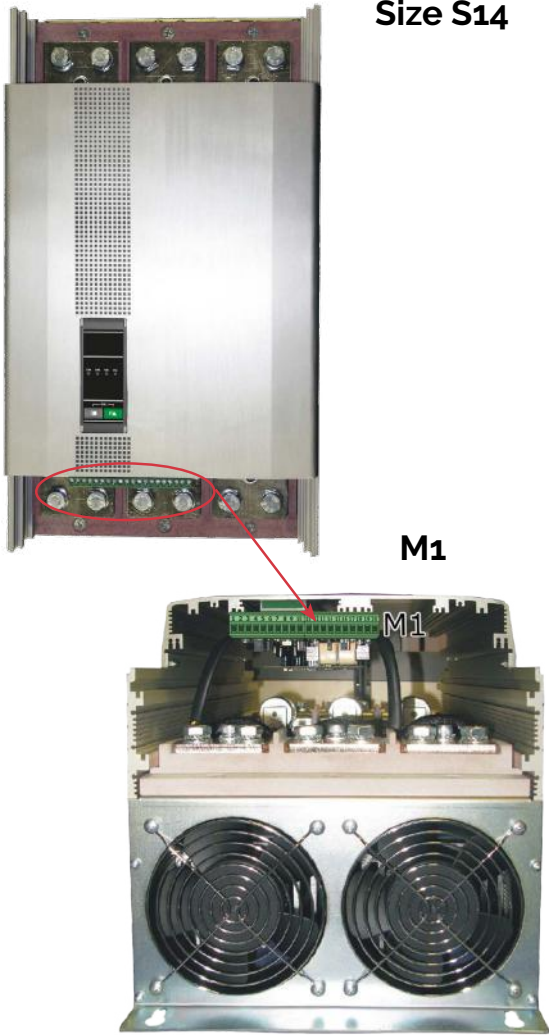

Open and flip the cover

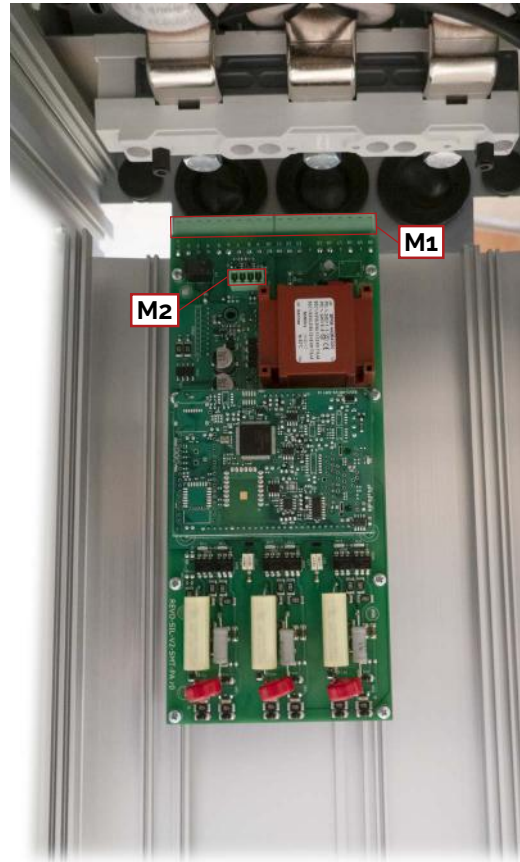

Size S16

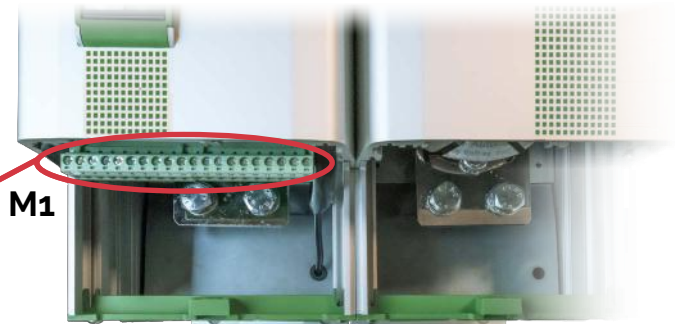

### 5.5 Power Terminals



**Warning:** Before connecting or disconnecting the unit check that power and control cables are isolated from voltage sources.

Terminal	Description
L1	Line Input Phase 1
L2	Line Input Phase 2 (only S14)
L3	Line Input Phase 3
T1	Load Output Phase 1
T2	Load Output Phase 2 - Not controlled by the thyristor (only S14)
T3	Load Output Phase 3

**REVO-S 2PH  
300A-700A (S14)**



**REVO-S 2PH  
800A (S16)**



5.5.1 Bar dimensions - Size S14 (300-700A)

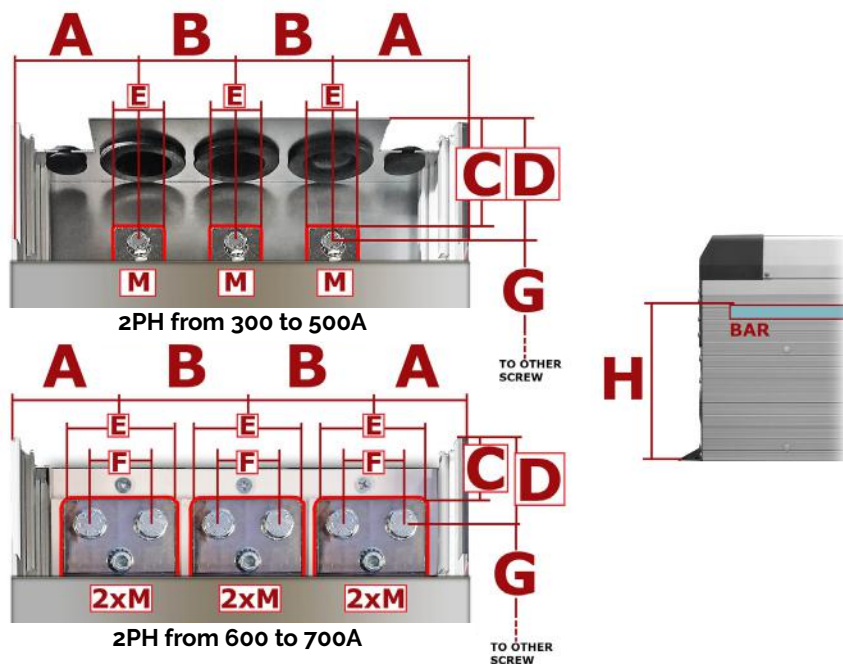

Current	A	B	C	D	E	F	G	H	M
300A (S14)	71mm	60mm	45mm	57mm	30mm	-	350mm	174mm	M10
400A (S14)	71mm	60mm	45mm	57mm	30mm	-	350mm	174mm	M10
450A (S14)	71mm	60mm	45mm	57mm	30mm	-	350mm	174mm	M10
500A (S14)	71mm	60mm	45mm	57mm	30mm	-	350mm	174mm	M10
600A (S14)	54mm	76mm	21mm	37mm	66mm	35mm	390mm	165mm	M10
700A (S14)	54mm	76mm	21mm	37mm	66mm	35mm	390mm	165mm	M10

5.5.2 Bar dimensions - Size S16 (800A)

Current	A	B	C	D	E	F	G	H	M
800A (S16)	69 mm	138 mm	50 mm	66 mm	66 mm	35 mm	380 mm	170 mm	M10

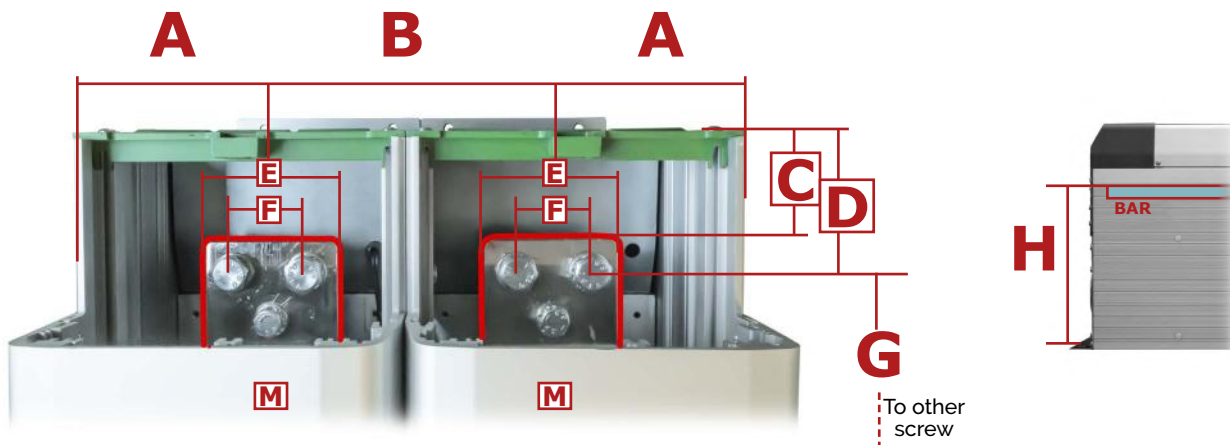

## 5.6 Control Terminals



**Warning:** Before connecting or disconnecting the unit check that power and control cables are isolated from voltage sources.

### M1

Terminal	Description
1	NO - Normally Open contact alarm relay output (HB)
2	C - Common contact alarm relay output
3	NC - Normally Close contact alarm relay output (HB)
4	Not Connected
5	DI 2 - Enable Digital Input
6	DI 1 - Configurable Input
7	Not Connected
8	Not Connected
9	Output +10Vdc stabilized 1 mA MAX
10	0V GND

Terminal	Description
11	- Analog Input 1 (0-10Vdc/4-20mA Analog Setpoint)
12	+ Analog Input 1 (0-10Vdc/4-20mA Analog Setpoint)
13	COM I - Common Digital Input
14	Not Connected
15	Fan supply (230V Standard - 115 Option - for DC Fan Option +24Vdc)
16	Fan supply (230V Standard - 115 Option - for DC Fan Option -24Vdc)
17	Not Connected
18	Aux - Voltage Supply for electronic boards (See order code for the Value)
19	Not Connected
20	Aux - Voltage Supply for electronic boards (See order code for the Value)

### M2

Terminal	Description
1	24V Out Max 5mA
2	Slave Output
3	Not Connected
4	0V GND

### 5.7 Schematic (S14: 300-700A)



**Caution:** this procedure must be performed only by qualified persons.



**Indicative connection diagrams. Refer to local regulations for proper system protection.**

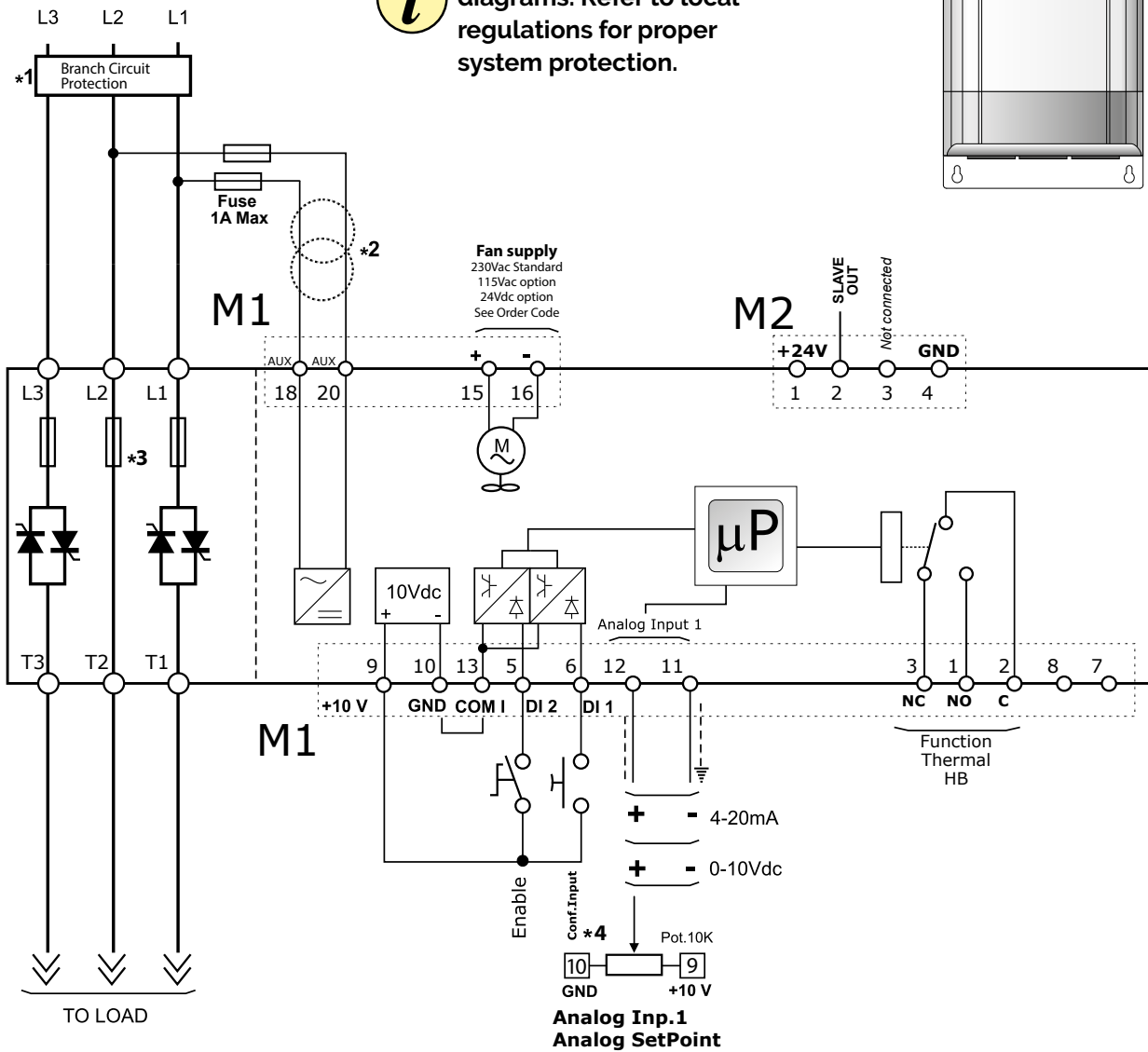
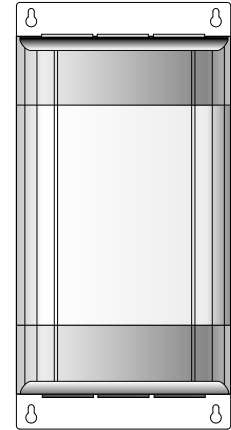

**NOTE**

- \*1 The user installation must be protecting by electromagnetic circuit breaker or by fuse isolator. The Fuse must be branch circuit protection. For UL any listed UL branch circuit fuse would be acceptable as an external fuse, following national electric code guide for resistive heating of 125% load current rating to protect external wires.
- \*2 If the Auxiliary Voltage (written on the identification label) is different from Supply Voltage (to the load), use an external transformer as designated.
- \*3 On phase L2 fuse not available for size 600-700A.
- \*4 For SSR input connection follow next page schematic.



### 5.7.1 SSR Control Input schematic

For SSR input use follow the schematic below and configure Digital Input 1 as Fast Enable.

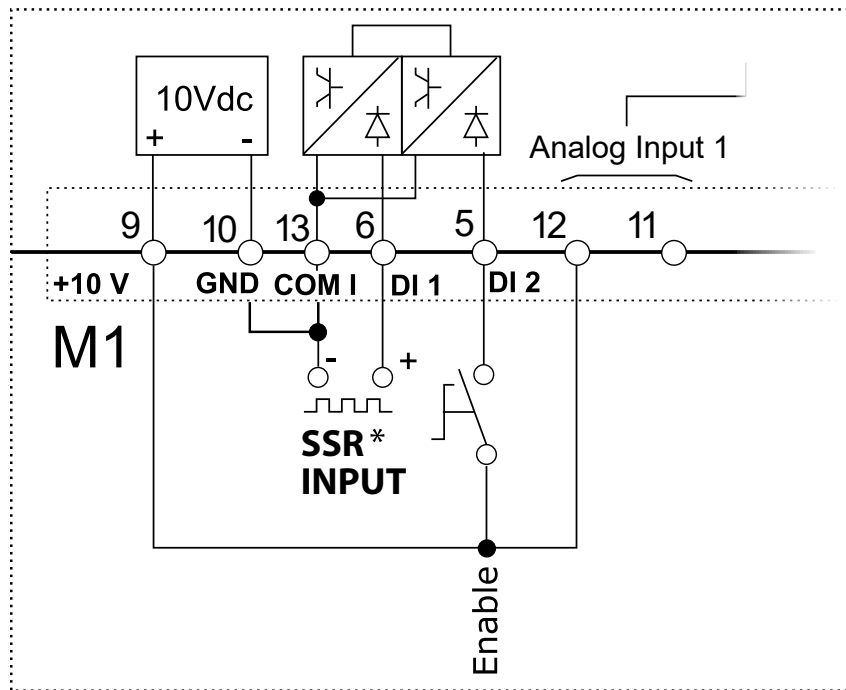

\* **SSR Input:** 4÷30Vdc 5mA Max (ON  $\geq$ 4Vdc / OFF  $<$ 1Vdc)  
 Frequency 3Hz Max - On time min. 100 ms

### 5.8 Connection Diagram for 3 phases (control on 2 phases) (Size S14)



**Caution:** this procedure must be performed only by qualified persons.

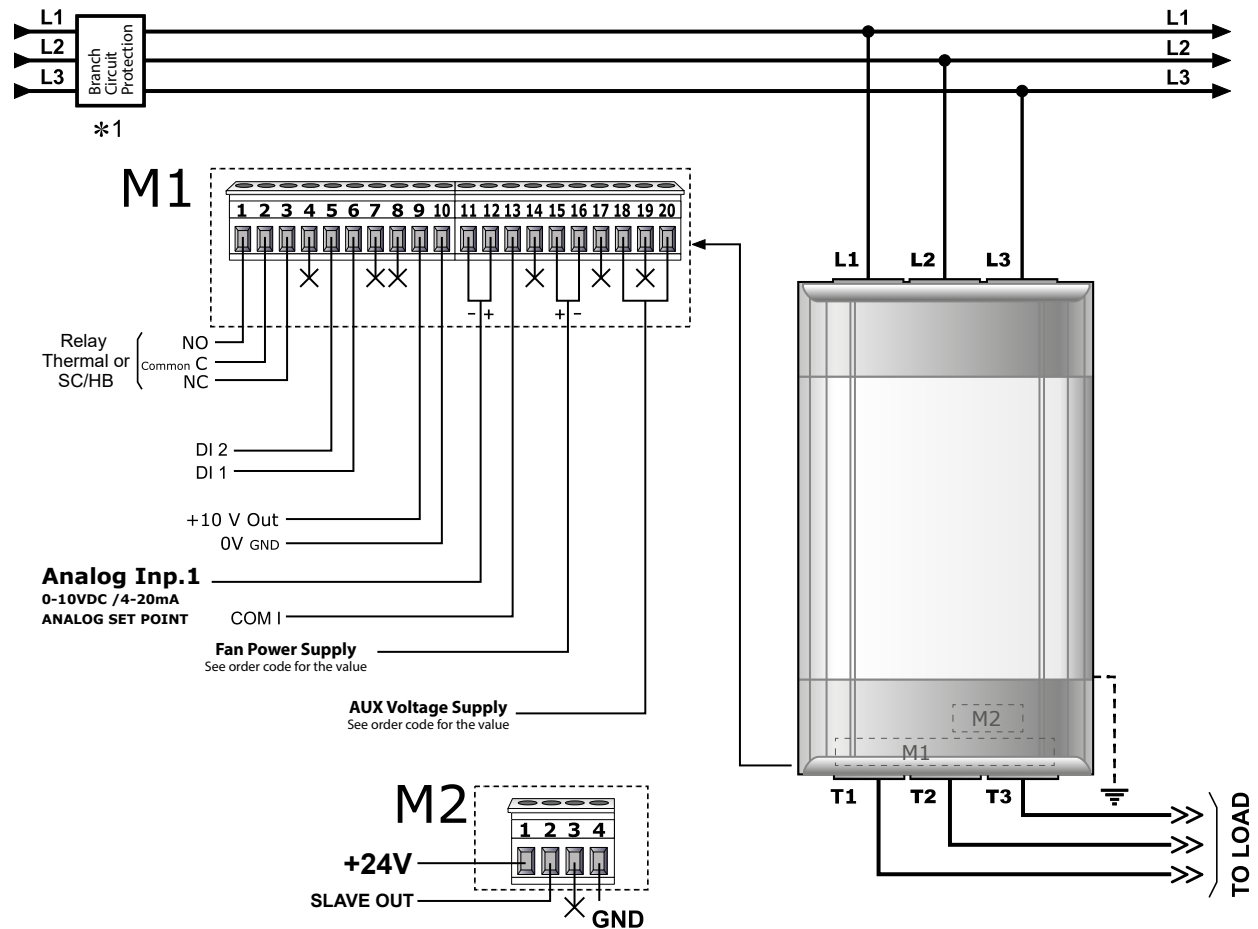

**Note:** Aux Voltage and Load Voltage must be synchronized

X = not connected

\*1 The user installation must be protecting by electromagnetic circuit breaker or by fuse isolator. The Fuse must be branch circuit protection. For UL any listed UL branch circuit fuse would be acceptable as an external fuse, following national electric code guide for resistive heating of 125% load current rating to protect external wires.

#### Load Type

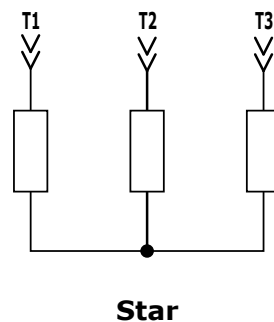
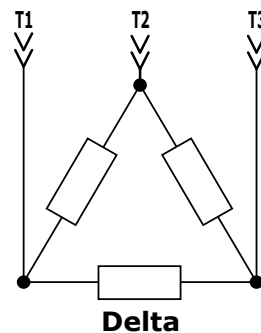

### 5.9 Schematic (S16: 800A)



**Caution:** this procedure must be performed only by qualified persons.



**Indicative connection diagrams. Refer to local regulations for proper system protection.**

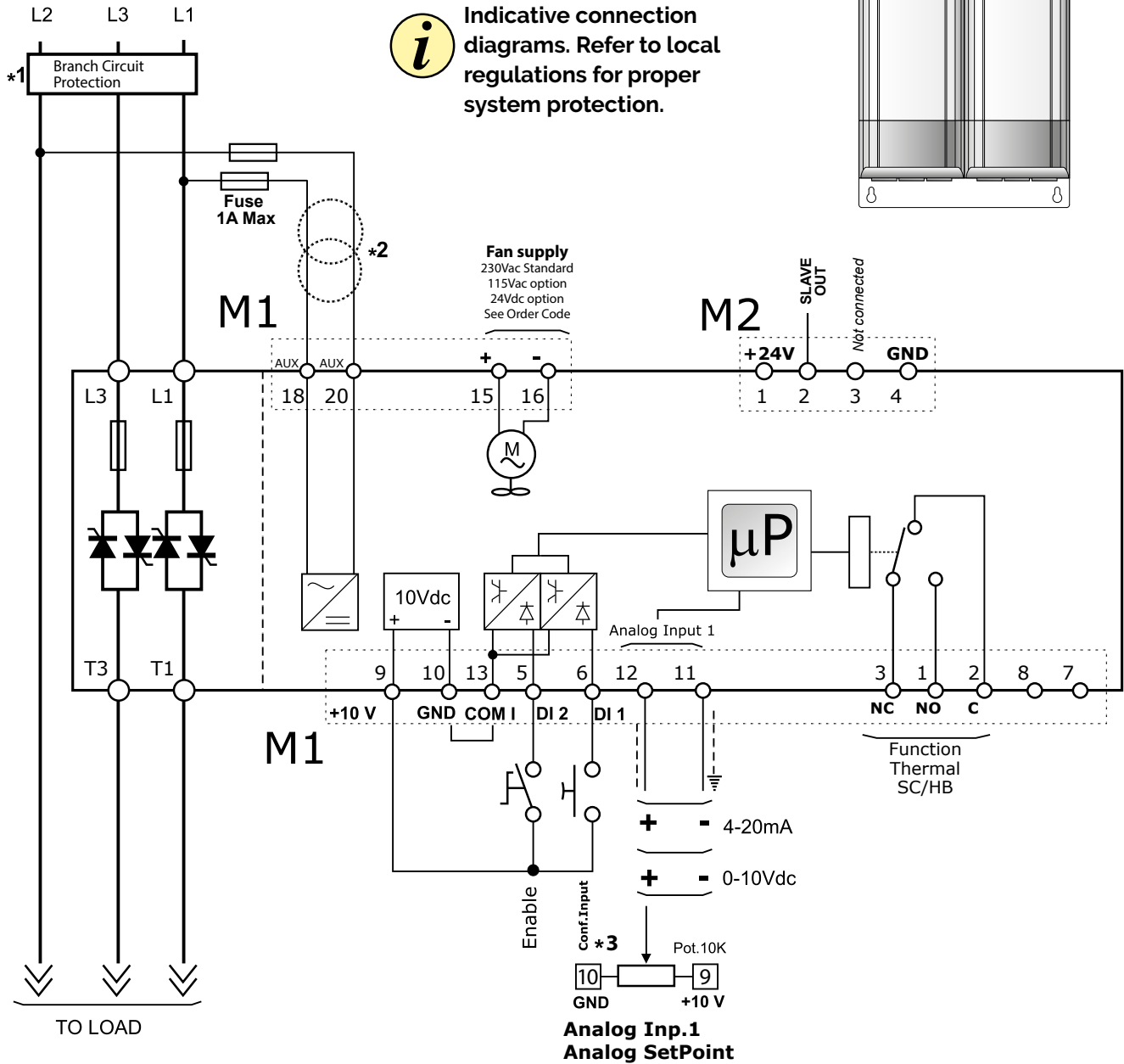
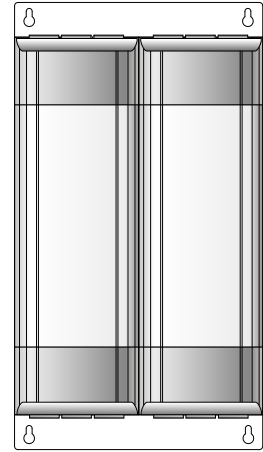

**NOTE**

- \*1 The user installation must be protecting by electromagnetic circuit breaker or by fuse isolator. The Fuse must be branch circuit protection. For UL any listed UL branch circuit fuse would be acceptable as an external fuse, following national electric code guide for resistive heating of 125% load current rating to protect external wires.
- \*2 If the Auxiliary Voltage (written on the identification label) is different from Supply Voltage (to the load), use an external transformer as designated.
- \*3 For SSR input connection follow next page schematic.

### 5.9.1 SSR Control Input schematic

For SSR input use follow the schematic below and configure Digital Input 1 as Fast Enable.

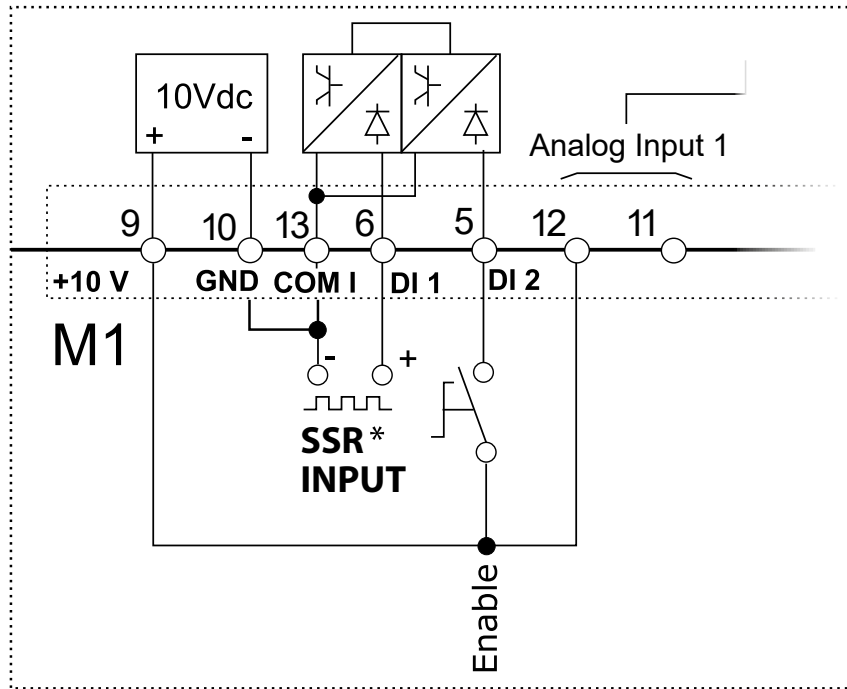

\* **SSR Input:** 4 ÷ 30Vdc 5mA Max (ON ≥4Vdc OFF <1Vdc)  
3HZ Max on time min. 100 ms

### 5.10 Connection Diagram for 3 phases (control on 2 phases) (Size S16)



**Caution:** this procedure must be performed only by qualified persons.

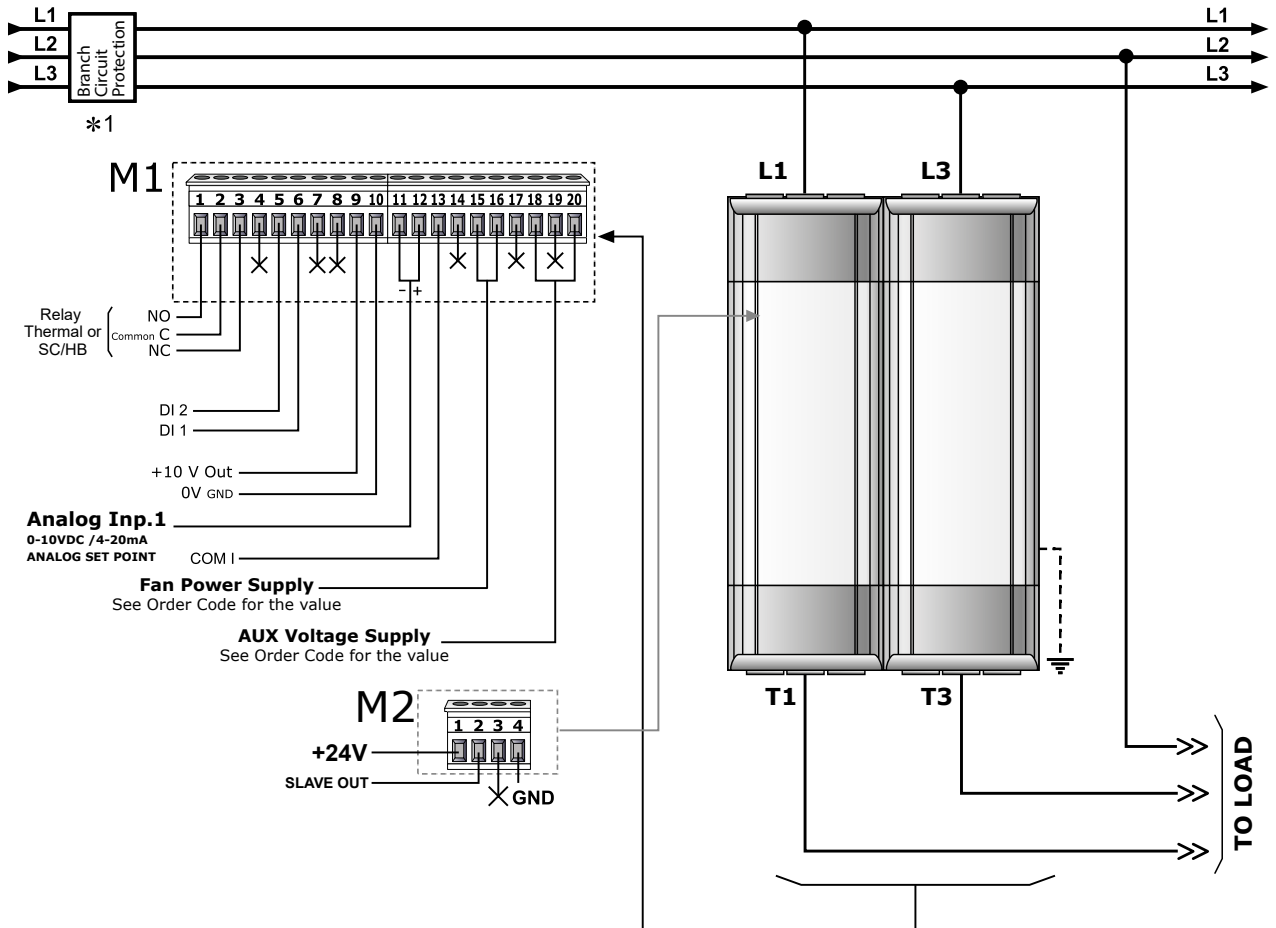

**Note:** Aux Voltage and Load Voltage must be synchronized

X = not connected

\*1 The user installation must be protecting by electromagnetic circuit breaker or by fuse isolator. The Fuse must be branch circuit protection. For UL any listed UL branch circuit fuse would be acceptable as an external fuse, following national electric code guide for resistive heating of 125% load current rating to protect external wires.

#### Load Type

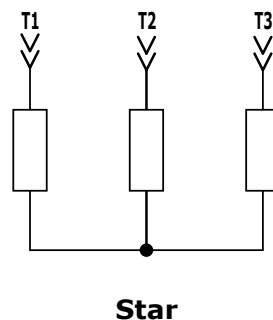
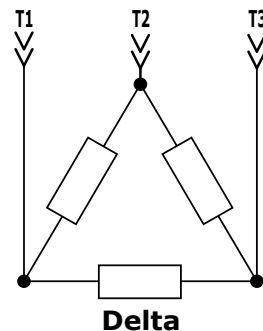

# 6 Led status and alarms

LED status

LED	STATUS	DESCRIPTION
EN	LED Flashing (◻)	Waiting for Enable Signal
	LED ON (■)	Enable Signal to terminal
ON	LED OFF (◻)	Load is NOT powered
	LED ON (■)	Load is powered
SC	LED OFF (◻)	Load OK
	LED ON (■)	SCR short circuit (only with HB option)
	LED Flashing (◻)	Enable contact open or Over temperature on heat sink
HB	LED OFF (◻)	Load OK
	LED ON (■)	Load Fault (only with HB option)

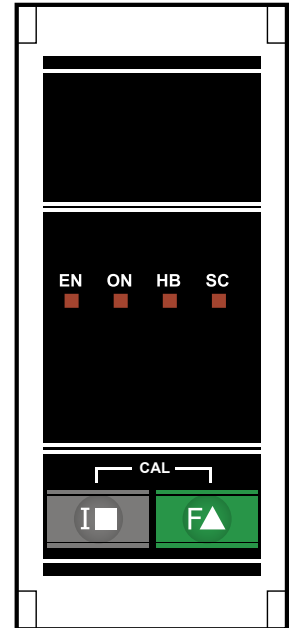

### Input type informations

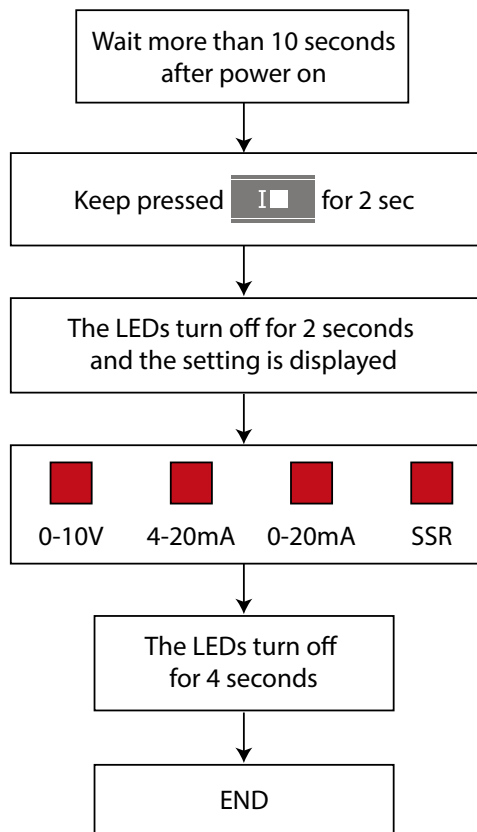

### Burst Firing informations

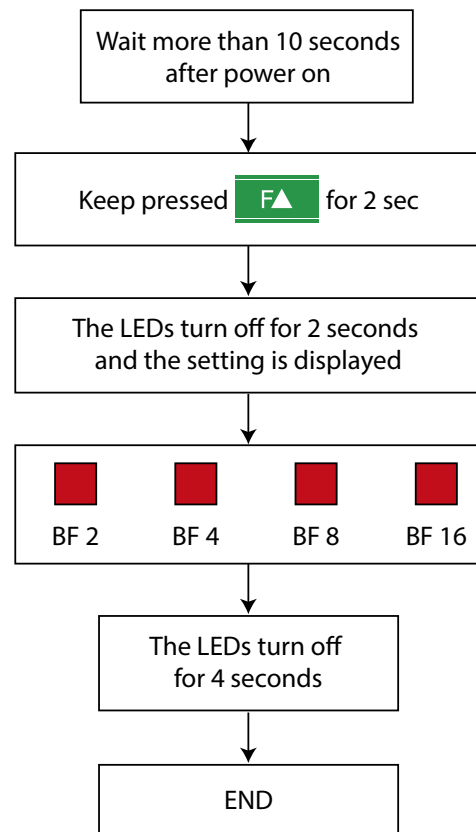

## 7

## Heater Break alarm and SCR short circuit

(HB Option only)



**Caution:** to work properly the load must be powered at least about 160msec.

The Heater Break circuit read the load current with an Internal current transformer (C.T).  
Minimum current is 10% of the current transformer size.  
If load current is below this value the Heater Break Alarm doesn't work properly.

### 7.1 Heater break Calibration procedure

An automatic function sets the Heater Break Alarm.

The auto setting function can be activated by pressing the keys  +  simultaneously for 4 seconds.

The Heater Break calibration procedure is performed in this way:

- The Unit gives the maximum voltage output
- The leds light up in sequence until the procedure is completed
- The current and voltage value is stored in memory
- After about 15 second the unit comes back to the initial situation

If load resistance increase more than 20% (sensitivity 20%) the HB LED become ON and alarm relay change status.

If the unit is still in conduction with no input signal (ON LED OFF) it means that there is a short circuit on thyristors and SC LED become ON.

If the load has been changed the Heater Break calibration procedure must be done again.

The HB Alarm is detected with minimum ON time 100 ms

# 8 Input Setting

The Input type is already configured in line with customer requirements that are defined in the order code. However, if you need to make changes you must follow the following procedure.

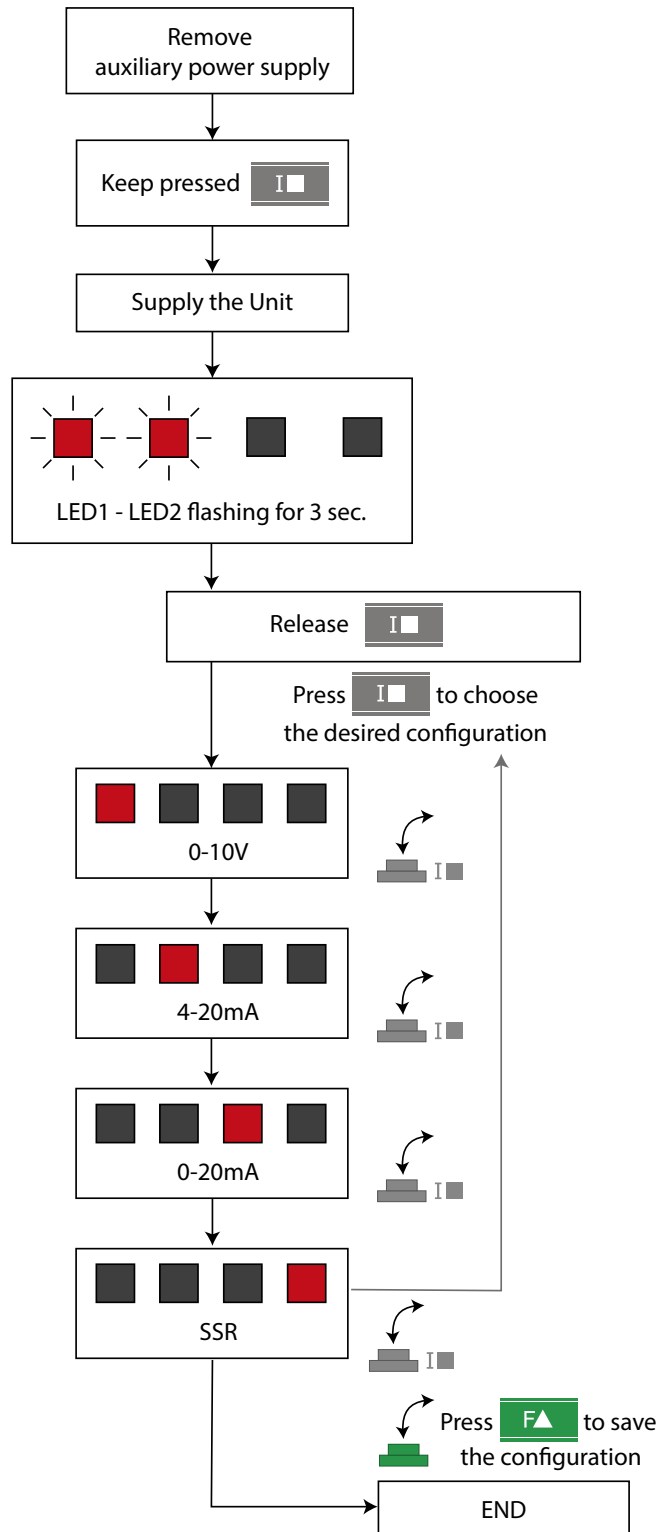



# 9 Burst Firing settings

The Burst Firing cycles is already configured in line with customer requirements that are defined in the Order Code. However, if you wish to change the Burst Firing cycles (es. from 4 to 8) you must follow the following procedure.

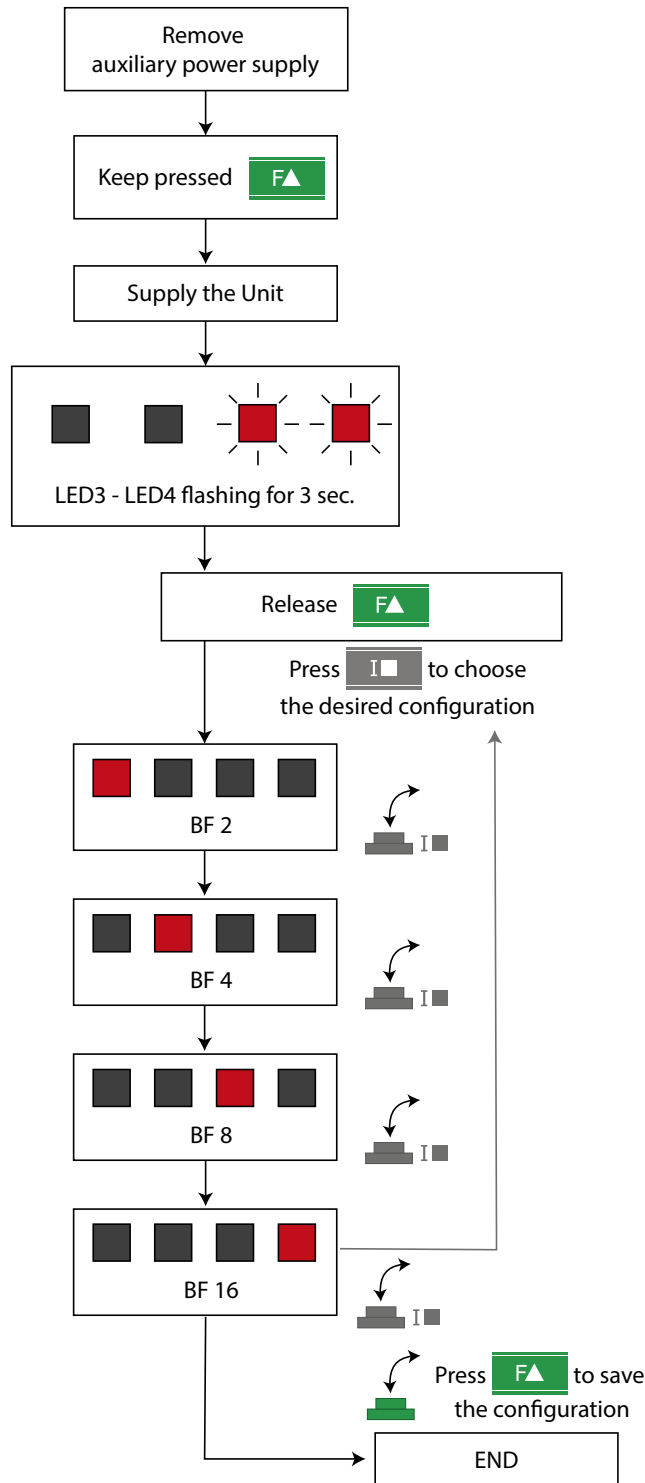

# 10 Firing type

Choose a correct firing type allows to optimize the thyristor unit for the installed load. The firing type has already configured in line with customer requirements Zero Crossing for SSR input and Burst Firing for Analog Input.



**Caution:** this procedure must be performed only by qualified persons.

## 10.1 Zero Crossing (ZC) with SSR input

ZC firing mode is used with Logic Output from temperature controllers and the Thyristor operates like a contactor.

The Cycle time is performed by temperature controller. ZC minimizes interferences because the Thyristor unit switches ON-OFF at zero voltage.

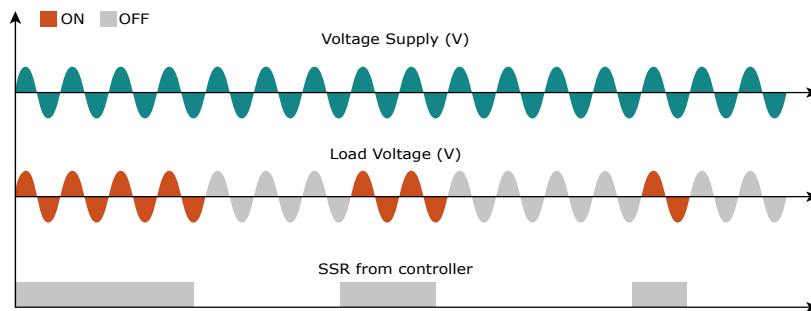

## 10.2 Burst Firing (BF) with Analog Input

The Burst Firing is similar to the Single Cycle, but consecutive cycles ON are selectable between 1 and 255, with input signal equal at 50%. When is specified 1 the firing type is Single Cycle.

Burst Firing is a method zero crossing that it reduces the electromagnetic interferences because the thyristor switches at zero voltage crossing.

The example show the Burst Firing with Burst cycles: 4.

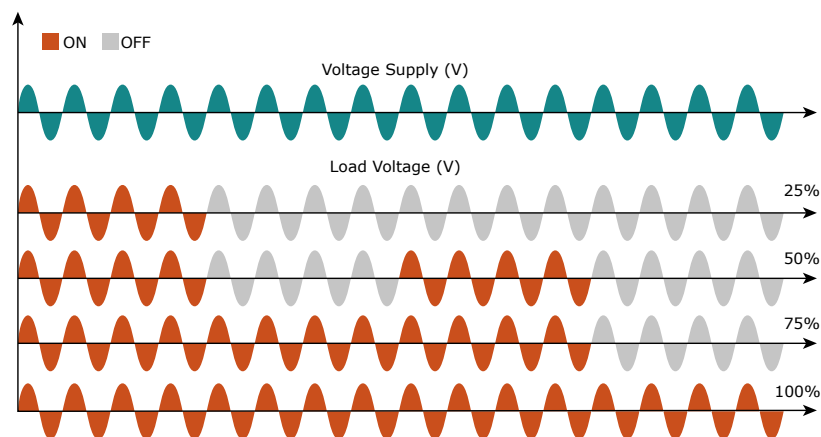

# 11 Supply the electronic board

The REVO S thyristor unit, to work, requires a voltage supply for the electronic boards. The Max consumption is 10VA. The voltage supply for the electronic boards is configured in line with customer requirements that are defined in the Order Code. The Order Code is written on the identification label.



- **Warning:** Before connecting or disconnecting the unit check that power and control cables are isolated from voltage sources.
- **Specialised personnel only**

Terminal M1	Description
18	Voltage Supply for Electronic Boards (Auxiliary Voltage)
19	Not Used
20	Voltage Supply for Electronic Boards (Auxiliary Voltage)

If it is necessary to change the value of the auxiliary supply voltage, move the jumpers as shown in the table below.

The range of the auxiliary voltage that can be set depends on the transformer mounted on the board, see the ordering code on Digit 8 (see table).

Order Code	As ordered		Change to	
	Jumper JP1 + JP2 are linked		Link only Jumper JP3	
	Transformer range	Line voltage	Transformer range	Line voltage
RS2_ _ _ - <b>1</b>	90:135V	100/120V	180:265V	200/208/220/230/240V
RS2_ _ _ - <b>2</b>	180:265V	200/208/220/230/240V	342:528V	380/400/415/440/480V
RS2_ _ _ - <b>3</b>	238:330V	277V	540:759V	600/690V
	Only Jumper JP3 is linked		Link Jumper JP1 + JP2	
RS2_ _ _ - <b>5</b>	342:528V	380/400/415/440/480V	180:265V	200/208/220/230/240V
RS2_ _ _ - <b>6</b>	540:759V	600V	238:330V	277V
RS2_ _ _ - <b>7</b>	540:759V	690V	238:330V	277V

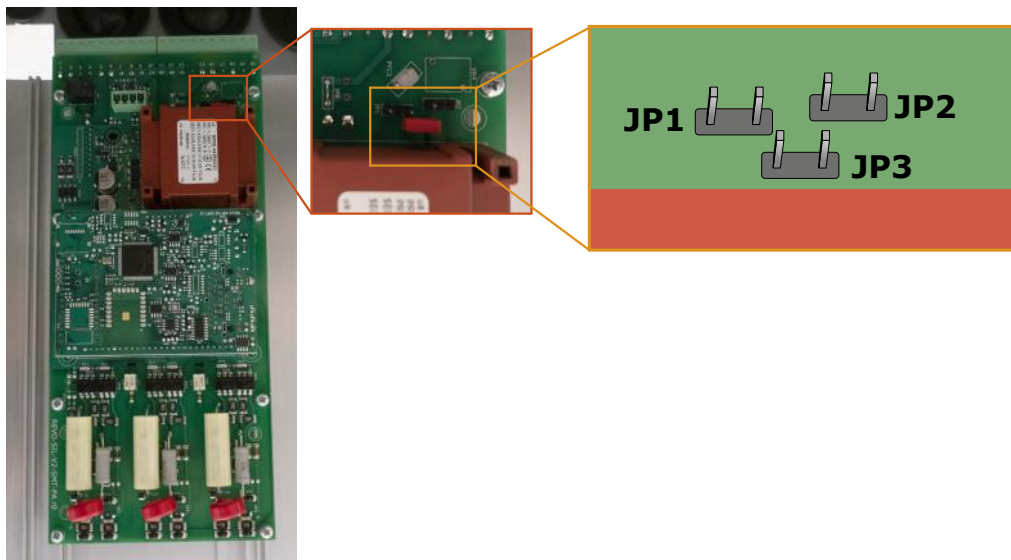

- **Attention!** never link all the jumpers JP1+JP2+JP3 at the same time or JP3 + any other jumper, JP3 must be always alone, follow only the configuration shown.
- **Attention!** The auxiliary voltage is also used for firing synchronism, so it must be in phase with the load voltage.

# 12 Internal Fuse

The thyristor unit have internal fuse extrarapid at low I<sup>2</sup>T for the thyristor protection of against the short-circuits. The Fuses must have I<sup>2</sup>T 20% less than thyristor's I<sup>2</sup>T. The warranty of thyristor is null if no proper fuses are used.

Size	200 kA <sub>RMS</sub> Symmetrical A.I.C.					Quantity for each phase
	Fuse CODE	Total Current (A <sub>RMS</sub> )	FUSE I <sup>2</sup> T value Suggested A2s (at 500V)*	FUSE I <sup>2</sup> T value Suggested A2s (at 660V)	Vac	
300A (S14)	FUFMM450	450	73500	105000	660	1
400A (S14)	FUFMM550	550	149000	215000	660	1
450A (S14)	FUFM315	630	215600	308000	660	2
500A (S14)	FUFM315	630	215600	308000	660	2
600A (S14)	FUFMM450	900	294000	420000	660	2
700A (S14)	FUFMM450	900	294000	420000	660	2
800A (S16)	FU2055920.250	1000	246400	352000	660	4

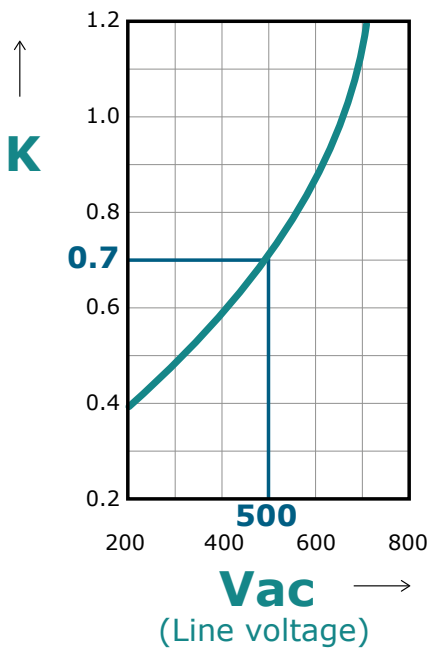

\*I<sup>2</sup>T are multiplied for K value in function of Vac at 500V K is equal to 0,7 (ex:105000 X 0,7 = 73500). At 660Vac K is equal to 1.

**Fuses replacement:** Open the cover and remove the screws, then replace it with the correct fuse, use the screws with a proper suggested torque indicated below

Type	Screw	Torque Lb-in (N-m)
300-800A	M8	133.7 (15.0)



**Caution:** High speed fuses are used only for the thyristor protection and can not be used to protect the installation.



**Caution:** The warranty of thyristor is null if no proper fuses are used. See tab.



**Warning:** When it is supply, the Thyristor unit is subject to dangerous voltage, don't open the Fuse-holder module and don't touch the electric equipments.





**CD Automation S.r.l.**

Via Picasso, 34/36 - 20025 Legnano (MI) - Italy

Tel. +39 0331 577479 - Fax +39 0331 579479

E-mail: [info@cdautomation.com](mailto:info@cdautomation.com) - Web: [www.cdautomation.com](http://www.cdautomation.com)